

## Model ST873 Dynaprobe™ pH and ORP For the Process Industries

**Description:**

The ST873 is a rugged, sealed sensor assembly designed for in-line or submersion applications. The patented solid state reference cell features the unique **IonTrap™** design for extended service life in the most severe applications. The body, with an integral 1" MNPT insertion thread, is molded from chemically resistant Ryton (PPS) and the reference junction is either porous Teflon or wood. Build-in temperature compensators are available. Optional sensor guard threads onto the front of the sensor and protects the sensor glass tip from impact. Sensor also available in ORP (Redox) version.

**Specifications :**

- pH Sensor Range:.....0 - 14 pH
- ORP Sensor Range:.....± 5000 mV
- Temp Range : .....0 - 140°C
- Max Pressure/Temp.....150 psig at 120°C
- Reference .....Ag-Agcl
- Wetted materials.....Ryton, Teflon or Wood, & Glass
- Std cable length.....10 feet

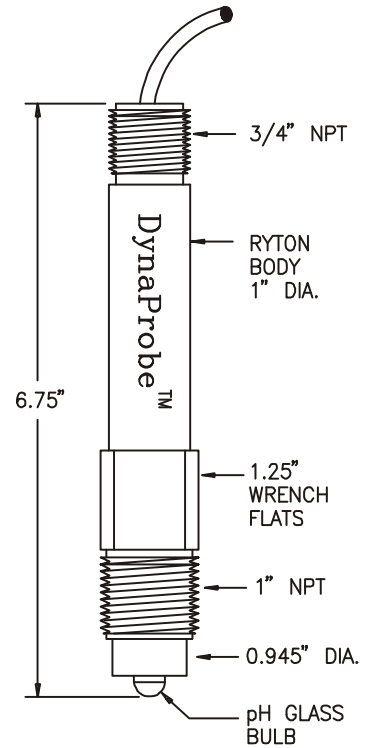

Model ST873

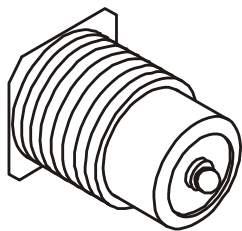

**Options.....**

**pH DynaProbe™ with Rugged Dome pH Bulb.**

**Choice of either Teflon or Wood Coaxial Liquid Junction.**

Designed to withstand the toughest industrial applications for best overall performance.

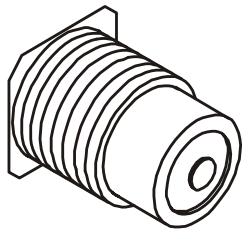

**pH DynaProbe™ with Flat pH Bulb**

**Choice of Teflon Coaxial Liquid Junction only.**

Designed for obstructionless contact with the sample stream for self cleaning service.

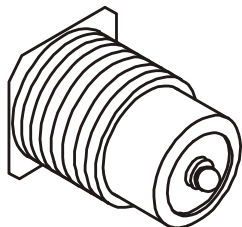

**ORP DynaProbe™ with Platinum Band**

**Choice of either Teflon or Wood Coaxial Liquid Junction.**

Designed for measuring the Oxidation-Reduction Potential of the sample.

# How to order the ST873 DynaProbe™

## Part Number Selection Guide

Specify DynaProbe™ Part Number here :

Category Position :

ST873     1     2     3     4     5     6     7     8     9

### CATEGORY SELECTION :

#### 1 Liquid Junction :

- [W] Coaxial Wood
- [T] Coaxial Teflon
- [R] Recessed Teflon

#### 2-3 Measurement Electrode:

- [33] pH, HT-3 Rugged Dome Bulb
- [43] pH, HT-4 High pH Bulb (for pH 13 and above)
- [17] pH, Flat Bulb/GP (use only w/"T" Coax Teflon Liq/Junct.) (100°C max temp range)
- [PB] ORP Platinum Band

#### 4 Temperature Compensator :

- [0] T.C. not required
- [1] 3KΩ for most older Models of TBI/Bailey, Uniloc and other US manufacturers
- [9] 301Ω for Grek Lakes Models 60, 70, 90, 570 and 690
- [D] Pt 100Ω for Beckman Model SoluComp, TBI/Bailey (ABB) TB82 & TB84, Uniloc 1054, Foxboro 870 & 874, yokogawa, and most European Models
- [H] Pt 1000 Ω for Yokogawa, Conducta, Polymetron, LTH, & many European models

#### 5 Cable Type:

- [A] Low Noise Coax for pH and ORP (No. T.C.)
- [E] Jacketed Coax Cable w/ TC leads.

#### 6-7 Cable Length:

- [10] 10 ft. is standard length  
Note : Preampfire require for longer length

#### 8-9 Required Sensor Cable Connectors :

- [BC] BNC only (for use with ORP electrodes or with sensors w/o TC or solution ground)
- [FB] BNC for pH and ferrules on all other leads (for use With Terminal Block or Terminal Strip)
- [FF] All Ferrule connectors (for use with Terminal block Or Terminal Strip)

## SUBMERSION INSTALLATION

The Model ST873 is readily converted into a submersion sensor by the installation of a threaded bulb guard.

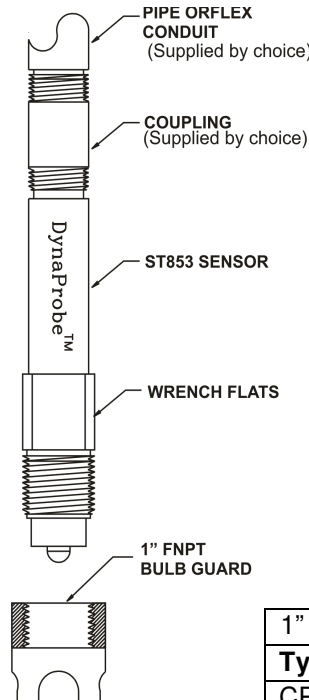

1" FNPT BULB GUARD	
Type	Part Number
CPVC	AM-9107
s.s	AM-9108

## IN-LINE INSTALLATION :

The Model ST873 is ready for an in-line sensor installation with the integral 1" MNPT insertion thread.

